

2017.5.14

2017년도 제3회 기침연구회 심포지엄

기침을 효과적으로 조절하는 약제

문 지 용

한양대학교구리병원 호흡기내과

Contents

기침약의 기전과 분류

기침약의 효능 평가방법

기침을 조절하는 약제들

Cough Suppression

- 기침의 원인을 고려하지 않고 기침을 억제하는데 중점
- 질병-특이적인 치료에 효과가 없을 때 시도해 볼 수 있는
방법

Peripheral Mechanisms of Cough

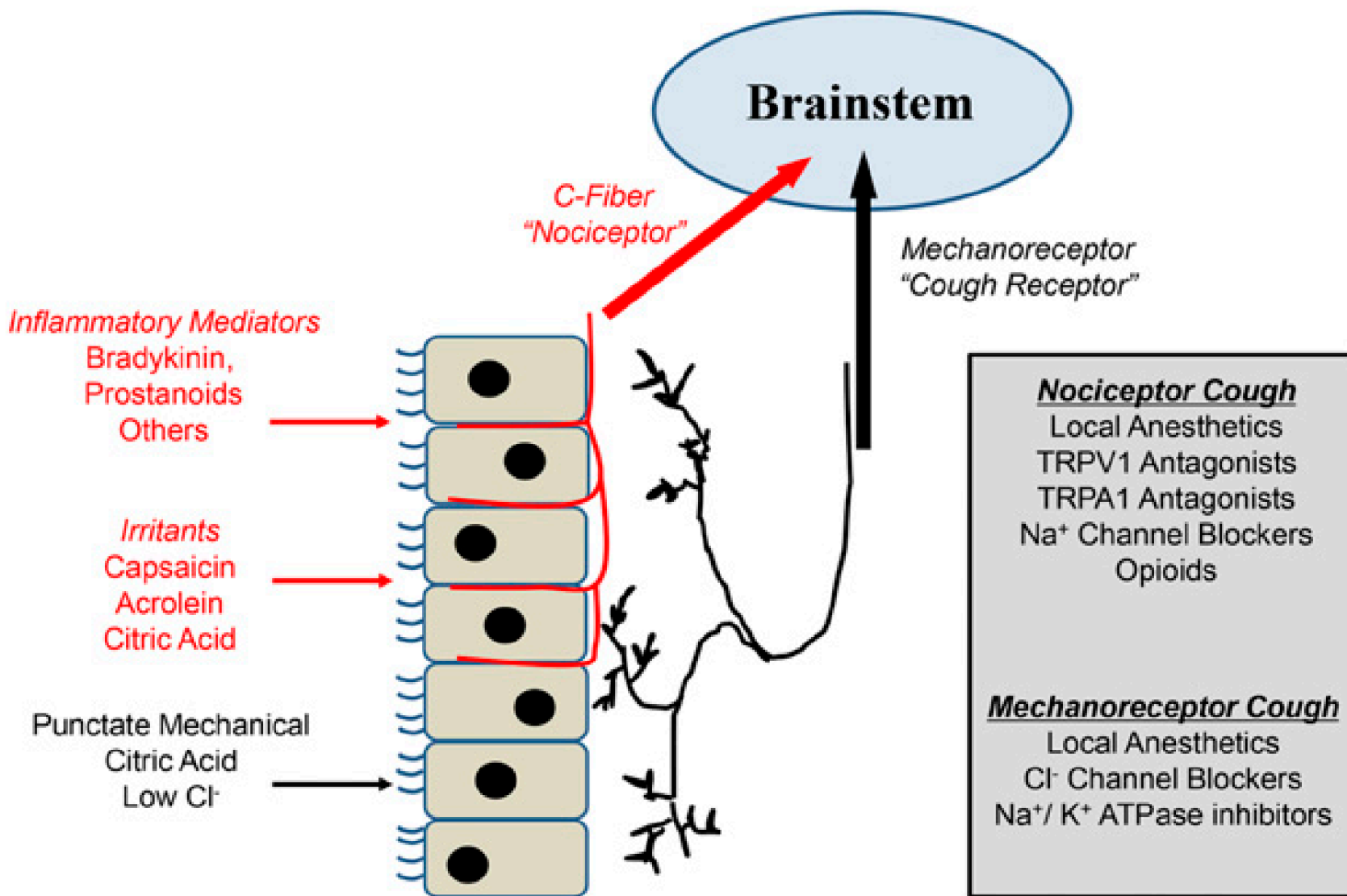

Central Mechanisms Regulating Cough

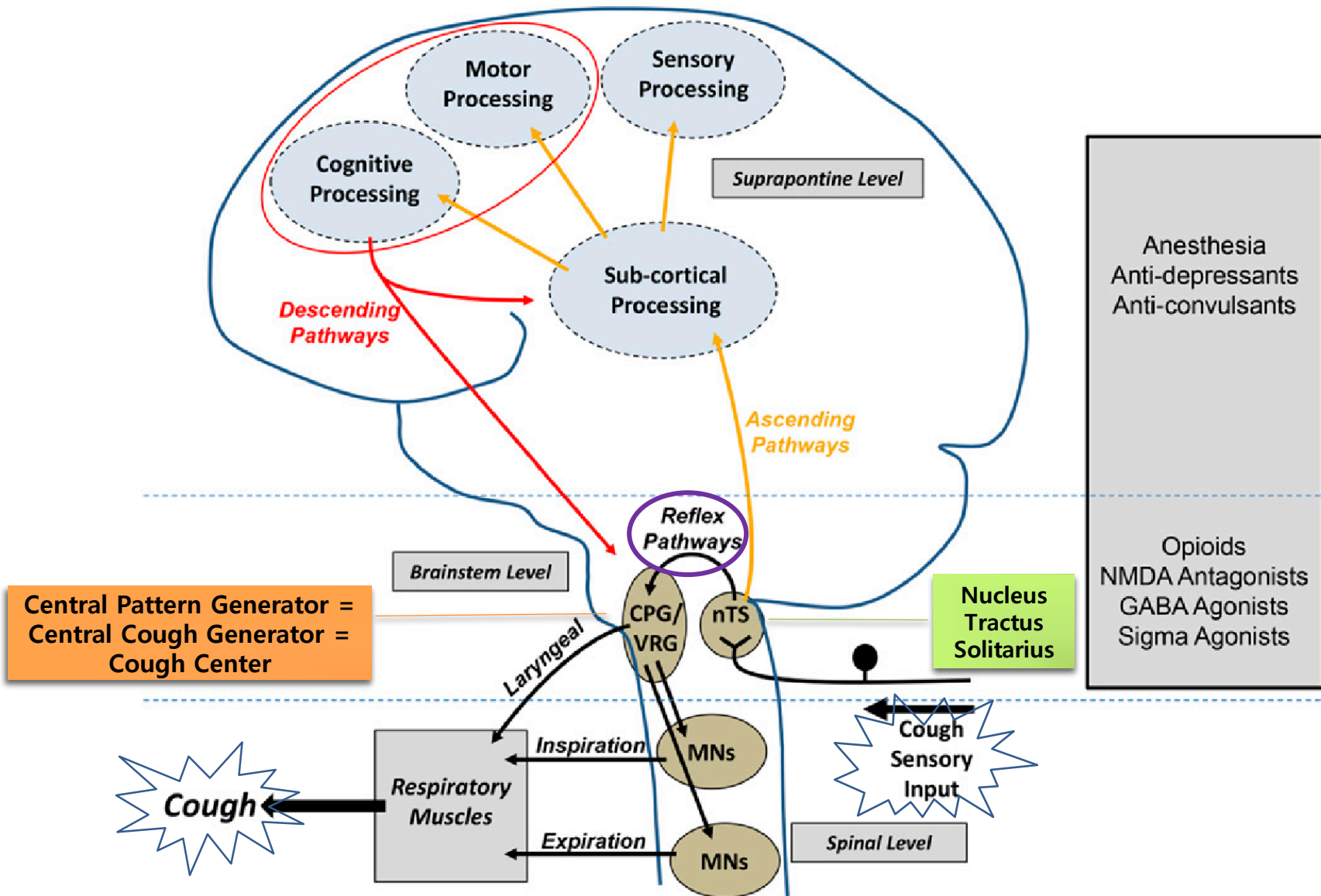

The Afferent and Efferent Pathways in the Control of Cough

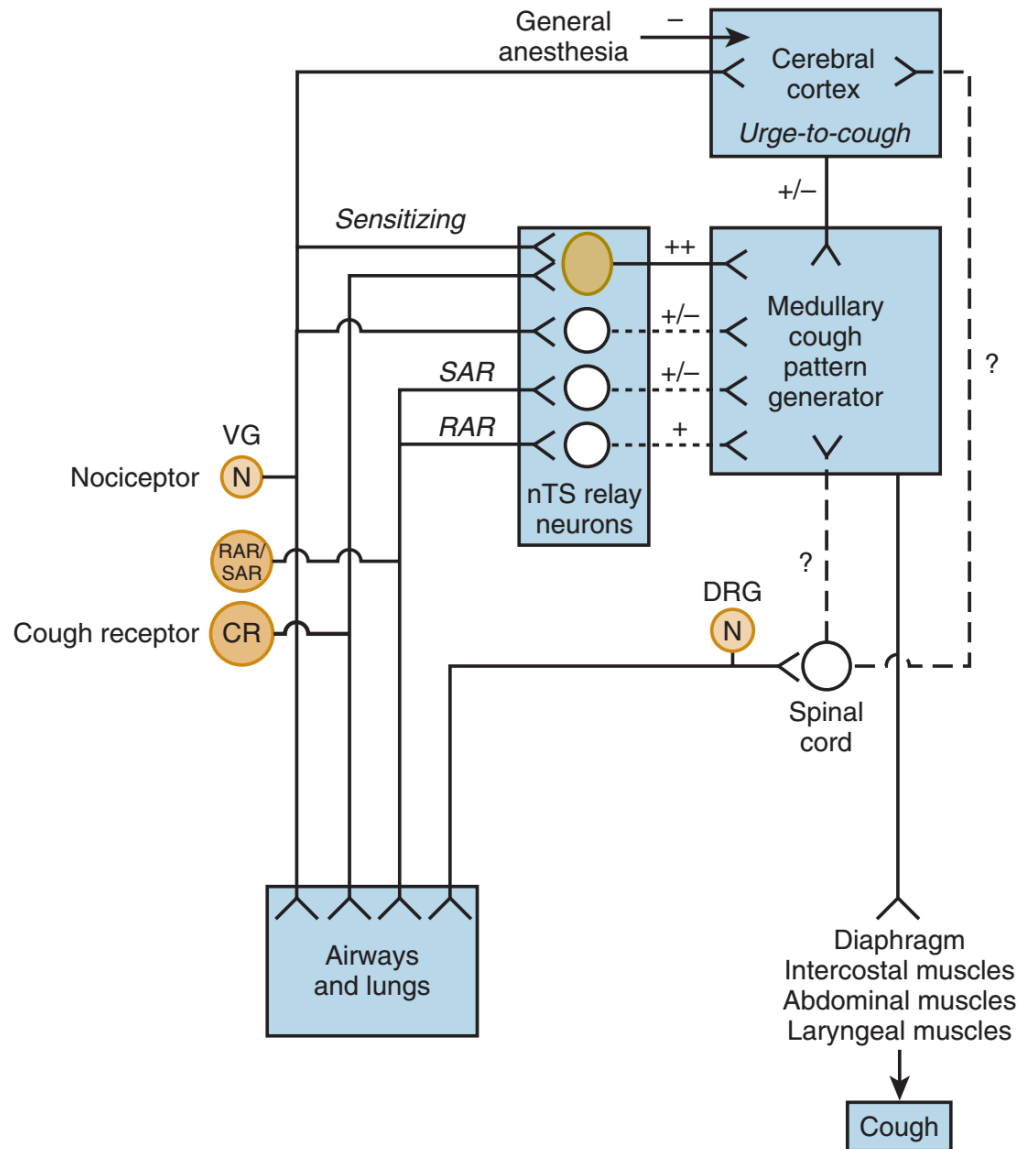

Action of Direct and Indirect Antitussives

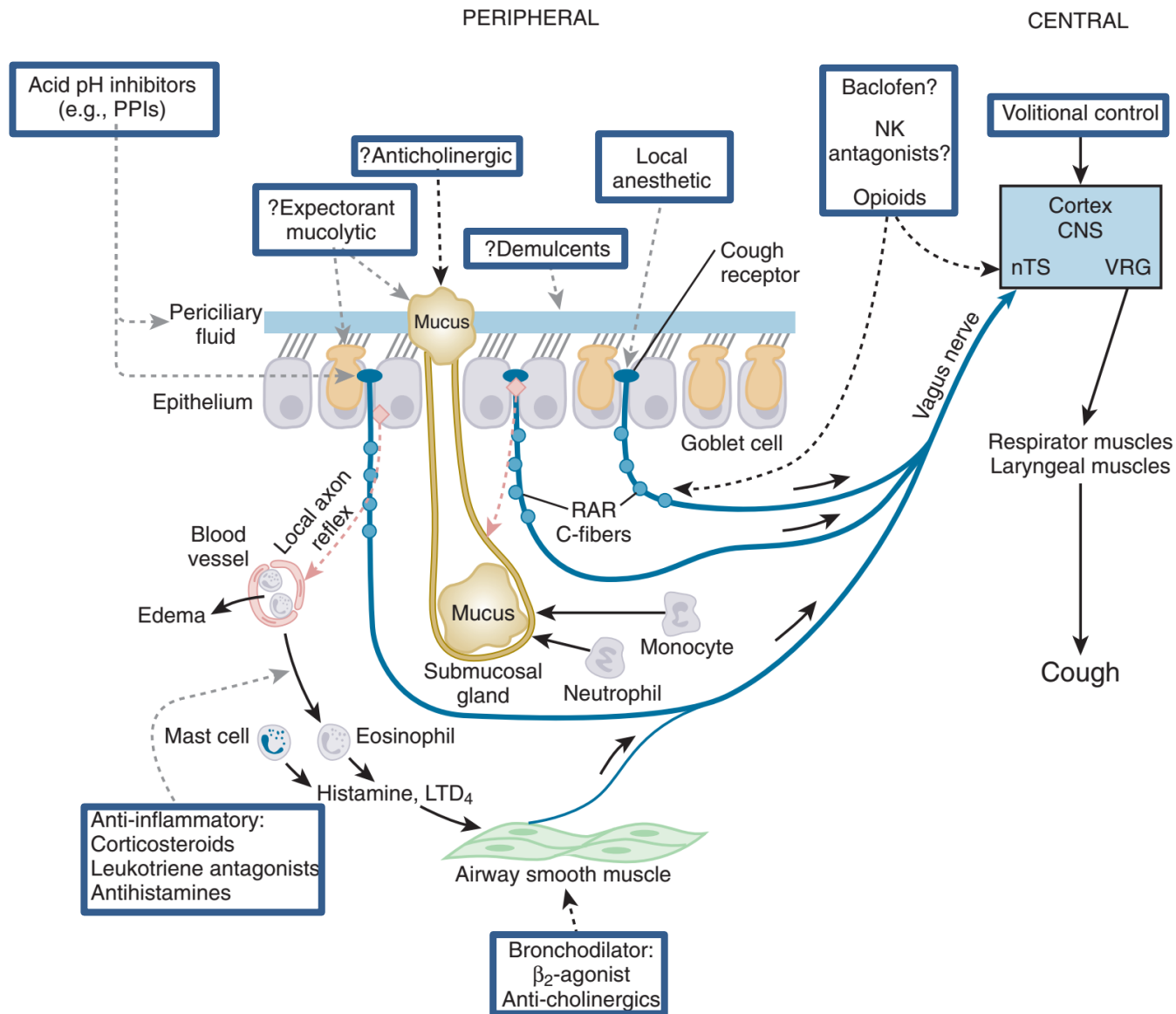

Contents

기침약의 기전과 분류

기침약의 효능 평가방법

기침을 조절하는 약제들

Assessment of Cough as Clinical Outcomes

- Invalidated methods for measuring cough
 - ◆ Subjective symptom measure
 - patient diaries, cough counts, and patient self reports

- Validated method of measuring cough
 - ◆ Cough frequency monitoring
 - Sound/movement recording and analysis
 - ◆ Impact of cough on quality of life
 - the Leicester Cough Questionnaire
 - ◆ Cough challenge testing
 - Capsaicin or citric acid

Subjective Symptom Scoring

TABLE I. Subjective cough scoring system for daytime and overnight cough

Score	Daytime	Score	Nighttime
0	No cough during the day	0	No cough during the night
1	Cough for 1 short period	1	Cough on waking only
2	Cough for more than 2 short periods	2	Wake once or early because of cough
3	Frequent coughing which did not interfere with usual daytime activities	3	Frequent waking because of coughs
4	Frequent coughing which did interfere with usual daytime activities	4	Frequent coughs most of the night
5	Distressing cough most of the day	5	Distressing cough most of the night

- 연구마다 조금씩 다름
 - ◆ 0-3의 4단계
 - ◆ 0-5의 6단계
 - ◆ 0-10의 11단계 (NRS, Numeric rating scale)
 - ◆ VAS (Visual analogue scale)

Cough Frequency Monitoring



Figure 4. Objective cough monitoring devices. (A) Accelerometer Cough Monitoring (Penn State College of Medicine, PA, USA), (B) Lifeshirt™ (Vivometrics, San Diego, CA, USA), (C) Leicester Cough Monitor (Glenfield Hospital, Leicester, UK), (D) CoughCOUNT™ (Karmelsonix Ltd, Haifa, Israel), (E) Vitalojak (Vitalograph Ltd, UK) and (F) Hull Automatic Cough Counter (Castlefield Hospital, Hull, UK). Adapted with permission from [18].

Development of a symptom specific health status measure for patients with chronic cough: Leicester Cough Questionnaire (LCQ)

S S Birring, B Prudon, A J Carr, S J Singh, M D L Morgan, I D Pavord

Thorax 2003;**58**:339-343

This questionnaire is designed to assess the impact of cough on various aspects of your life. Read each question carefully and answer by CIRCLING the response that best applies to you. Please answer ALL questions, as honestly as you can.

1. In the last 2 weeks, have you had chest or stomach pains as a result of your cough?

1	2	3	4	5	6	7
All of the time	Most of the time	A good bit of the time	Some of the time	A little of the time	Hardly any of the time	None of the time

2. In the last 2 weeks, have you been bothered by sputum (phlegm) production when you cough?

1	2	3	4	5	6	7
Every time	Most times	Several times	Some times	Occasionally	Rarely	Never

3. In the last 2 weeks, have you been tired because of your cough?

1	2	3	4	5	6	7
All of the time	Most of the time	A good bit of the time	Some of the time	A little of the time	Hardly any of the time	None of the time

4. In the last 2 weeks, have you felt in control of your cough?

1	2	3	4	5	6	7
None of the time	Hardly any of the time	A little of the time	Some of the time	A good bit of the time	Most of the time	All of the time

5. How often during the last 2 weeks have you felt embarrassed by your coughing?

1	2	3	4	5	6	7
All of the time	Most of the time	A good bit of the time	Some of the time	A little of the time	Hardly any of the time	None of the time

6. In the last 2 weeks, my cough has made me feel anxious

1	2	3	4	5
All of the time	Most of the time	A good bit of the time	Some of the time	A little of the time



Reliability and Validity of a Korean Version of the Leicester Cough Questionnaire

Jae-Woo Kwon,¹ Ji-Yong Moon,² Sae-Hoon Kim,^{3,4} Woo-Jung Song,⁴ Min-Hye Kim,⁵ Min-Gyu Kang,⁴ Kyung-Hwan Lim,⁶ So-Hee Lee,⁴ Sang Min Lee,⁷ Jin Young Lee,⁸ Hyouk-Soo Kwon,⁹ Kyung-Mook Kim,¹⁰ Sang-Heon Kim,² Sang-Hoon Kim,¹¹ Jae-Won Jeong,¹² Cheol-Woo Kim,¹³ Sang-Heon Cho,⁴ Byung-Jae Lee^{8*} on the behalf of Work Group for Chronic Cough, the Korean Academy of Asthma, Allergy and Clinical Immunology

이 설문지는 당신 삶의 다양한 측면에 대한 기침의 영향을 평가하기 위한 것입니다. 각 질문을 주의 깊게 읽고 귀하께 가장 잘 해당되는 답을 표시하시기 바랍니다.

1. 지난 2주 동안, 기침으로 인해 가슴통증이나 복통을 느낀 적이 있습니까?

1. 항상 2. 대부분 시간 3. 상당한 시간 4. 때때로 5. 약간 6. 거의 없음. 7. 전혀 없음.

2. 지난 2주 동안, 기침할 때 가래 때문에 불편했습니까?

1. 항상 2. 대부분 3. 여러 번 4. 때때로 5. 드물게 6. 거의 없음 7. 전혀 없음.

Cough Challenge Testing

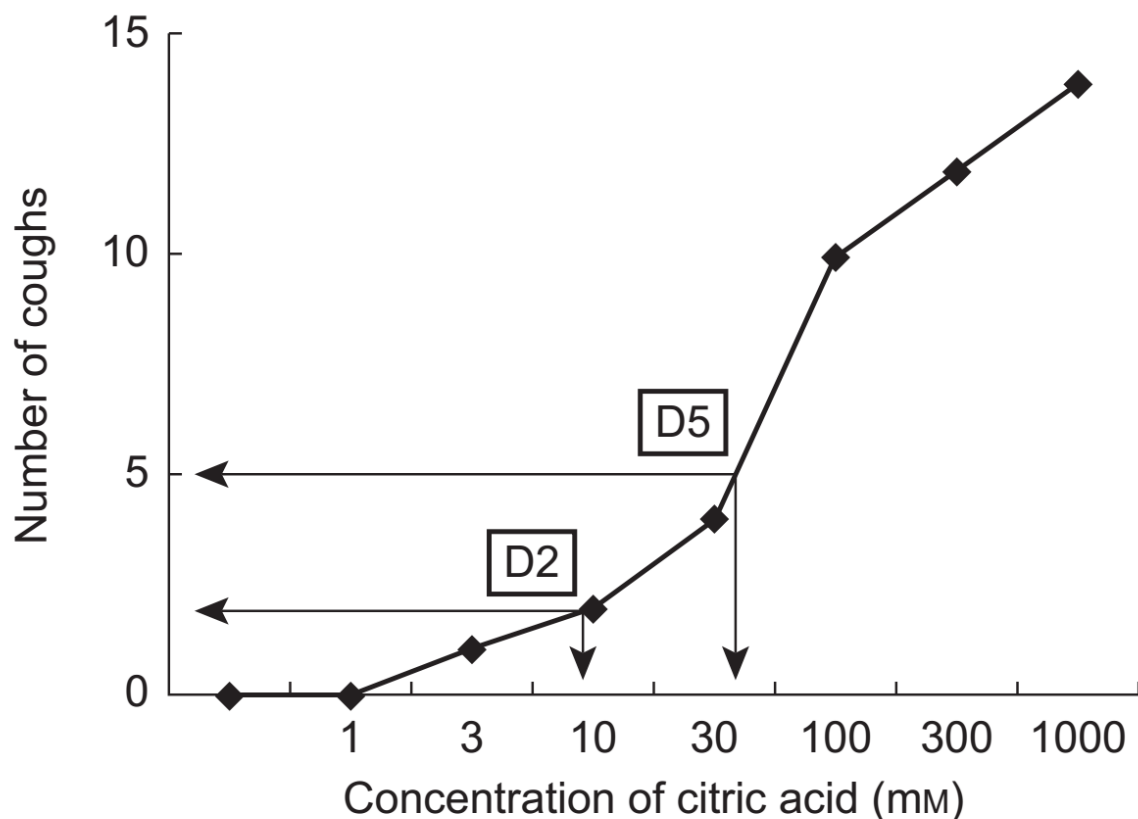

- 30초 간격으로 단계적으로 흡입 농도 증가
- 흡입 후 10초 동안 기침 횟수를 기록하여 2번과 5번 기침할 때의 농도 계산

Figure 1 An example of a dose-cough response curve constructed by linear interpolation during citric acid inhalation cough challenge. D2 = concentration of citric acid causing two coughs per inhalation, D5 = concentration of citric acid causing five coughs per inhalation.

Contents

기침약의 기전과 분류

기침약의 효능 평가방법

기침을 조절하는 약제들

Classification of Antitussive Agents

- Central-acting antitussive agents
 - ◆ Opioid
 - Morphine
 - Codeine
 - ◆ Non-opioid
 - Dextromethorphan
- Peripheral-acting antitussive agents
 - Levodropropizine
 - Theobromine
- Neuroleptics
 - Amitriptyline
 - Gabapentin
 - Pregabalin
 - Baclofen

Opiate

- 18세기 부터 기침약으로 사용되어 옴
- 작용 기전은 잘 알려지지 않았음
- adverse effects: drowsiness, difficulty concentrating, symptoms of the gall bladder, and constipation
- a risk of habituation or abuse
- 수면유도효과에 의한 기침억제는 아닌 것으로 추정됨

Opiate Therapy in Chronic Cough

Alyn H. Morice¹, Madhav S. Menon¹, Siobhan A. Mulrennan¹, Caroline F. Everett¹, Caroline Wright¹,

- ◆ a randomized double-blind placebo-controlled study
- ◆ 4 weeks of slow-release morphine sulfate (MST) vs. placebo
- ◆ Leicester Cough Questionnaire(LCQ), daily symptom diary, and citric acid cough challenge

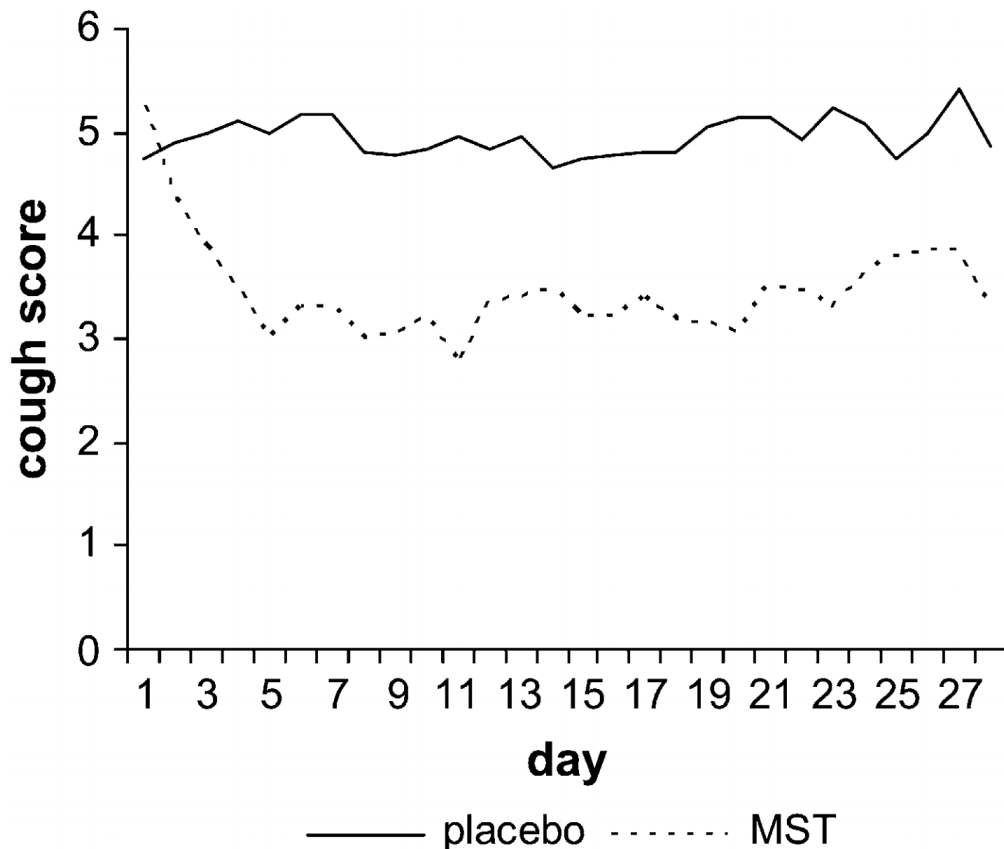

- ◆ Morphine sulfate is an effective antitussive in intractable chronic cough at the doses of 5 to 10 mg twice daily
- ◆ Well-tolerated medication; 25% reported drowsiness
- ◆ an insignificant change in cough reflex sensitivity

Codein

- 기침에 대해 가장 흔히 처방되는 약제
- 1960년대와 70년대의 작은 규모의 연구에서는 효과를 보였지만, 비교적 최근의 연구에서는 위약 대비 효과를 입증하지 못함
- cytochrome P4502D6 에 의해 대사가 되어 morphine으로 변환됨 -> 대사되는 정도가 사람마다 달라서 부작용과 효과도 사람마다 차이가 큼
 - ◆ 대사가 빠른 사람: 효과가 크지만 부작용도 잘 나타남
 - ◆ 대사가 느린 사람: 효과가 적지만 부작용도 적음

CONTROLLED CLINICAL TRIALS OF ANTITUSSIVE AGENTS: AN EXPERIMENTAL EVALUATION OF DIFFERENT METHODS

F. B. NICOLIS AND G. PASQUARIELLO

Medical Department, Clinical Research Division, Lepetit S.p.A, Milano, Italy

Received for publication June 20, 1961

- ◆ Study 1: Codeine (30mg qid) or placebo for 5 days, crossed over after a 3 day washout period (n=43)
- ◆ Study 2: Codeine (30mg qid) or placebo for 8 days crossed over every 3 days (n=56)
- ◆ Study 3: Codeine (60mg) or placebo single application. (3 separate groups of patients, n=85)

Expt.	Total No. of Subjects	No. of Subjects Whose No. of Coughs in 3 hr Was			No. of Coughs in 3 hr* (Mean \pm S.E.) after		Significance of Difference between Treatments†
		less after codeine	less after placebo	same after codeine and placebo	codeine	placebo	
I	30	23	5	2	6.4 \pm 1.2	11.7 \pm 1.5	P < .001
II	22	16	5	1	8.2 \pm 1.9	13.5 \pm 1.9	P < .001
III	33	25	5	3	9.8 \pm 1.6	14.5 \pm 1.9	P < .001

* The number of coughs is collected by an observer during the 2nd, 3rd and 4th hours after administration of each treatment.

† Evaluated by means of Wilcoxon's paired-sample rank test.

- ◆ Statistically significant difference in number of coughs in patients treated with a single dose of codeine (60mg) compared to placebo. However, 2 studies with lower codeine dosages over longer timeframes failed to identify a significant effect on cough
- ◆ no information about withdrawals or adverse events

Effect of codeine on objective measurement of cough in chronic obstructive pulmonary disease

Jaclyn Smith, MD, PhD,^a Emily Owen, MPhil,^a John Earis, MD,^b and Ashley Woodcock, MD^a

- ◆ double-blind, placebo-controlled crossover study
- ◆ 21 patients with physician-diagnosed, stable COPD who complained of cough (76.9% male; mean age, 67.7 yrs; mean predicted FEV1, 53.4%; median smoking history, 43.5PYs)
- ◆ Codeine phosphate 60 mg bid or matched placebo were given

TABLE III. Summary of measures of cough at baseline and after treatment with codeine and placebo, for day and night*

	Baseline	Placebo	Codeine
Cough frequency (cs/h), median (IQR)			
Day	13.8 (10.5-17.4)	11.1 (7.7-16.4)	10.7 (6.2-14.6)
Night	2.1 (1.0-4.3)	2.0 (0.9-3.5)	1.9 (1.1-3.6)
Cough score, mean (\pm SD)			
Day	2.8 (\pm 0.7)	2.7 (\pm 0.6)	2.8 (\pm 1.0)
Night	1.7 (\pm 1.0)	1.7 (\pm 1.2)	1.4 (\pm 0.9)
VAS (mm), median (IQR)			
Day	44 (32-66)	27 (11-61)	24 (11-63)
Night	12 (8-38)	17 (12-47)	7 (6-19)
Log C5 median (IQR)	-1.20 (-1.50 to -0.9)	-0.60 (-1.21 to -1.05)	-0.90 (-1.2 to -0.6)
Log C2 median (IQR)	-1.21 (-1.50 to -1.20)	-1.05 (-1.50 to -0.88)	-1.21 (-1.5 to -0.9)

*Cough frequency is quantified as time spent coughing in cs/h, cough score is as per Table I, and cough challenge result as \log_{10} of molar concentration of citric acid inducing 2 coughs (C2) and 5 coughs (C5), respectively.

Smith J, et al. *J Allergy Clin Immunol* 2006;117:831-5.

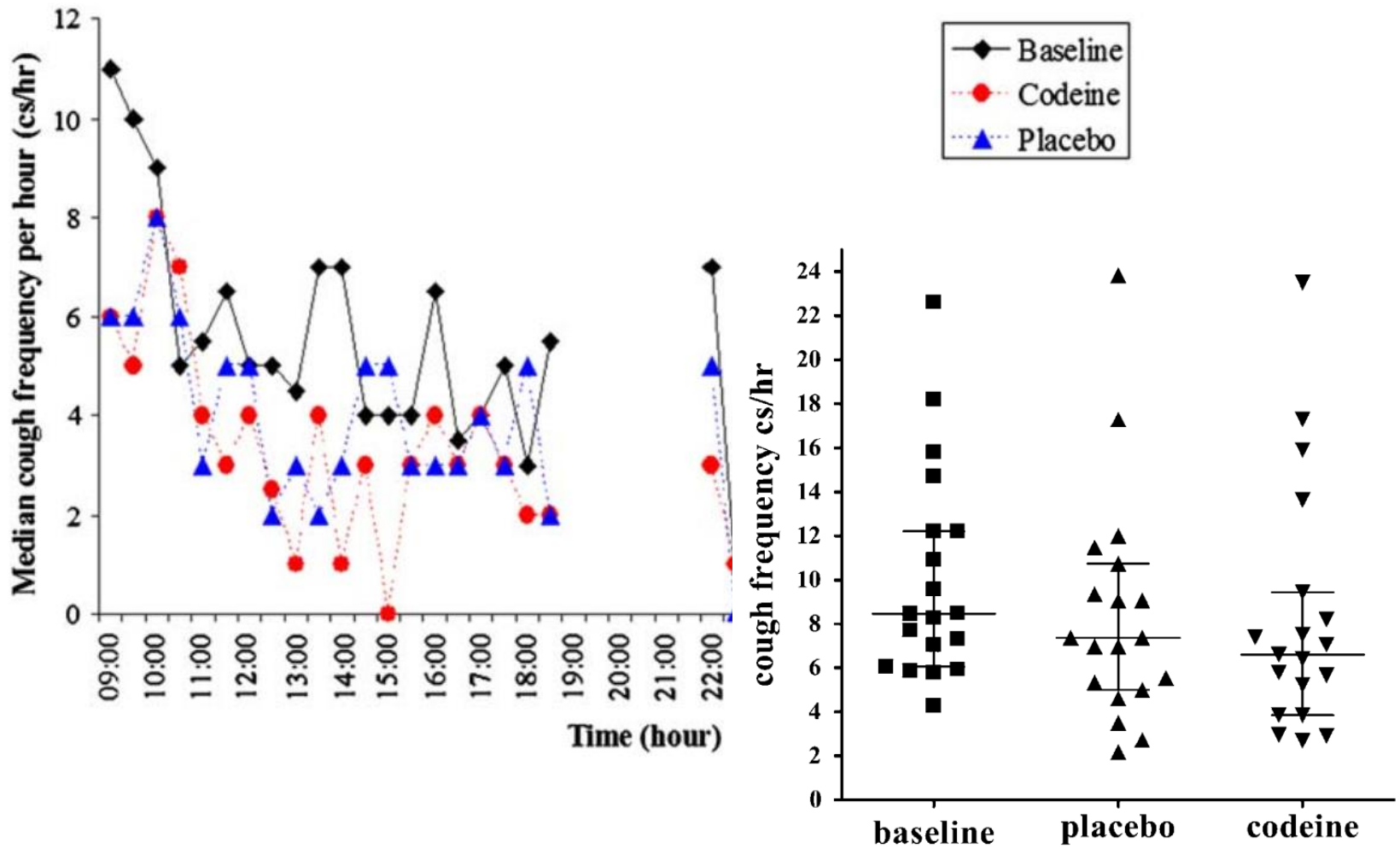

◆ codeine was no more effective than placebo in patients with COPD complaining of cough

Dextromethorphan

- non-opiate systemic antitussive
- 가장 많이 쓰이는 over-the-counter 기침억제제
- 정상인에서 citric acid에 의한 기침유발을 억제
(Grattan TJ, *et al.* Br J Clin Pharmacol 1995;39:261-3)
- 여러 지침에서 급성기침의 치료제로 제시됨
- 만성기침에 대해서는 연구가 거의 없음

Antitussive Efficacy of Dextromethorphan in Cough Associated with Acute Upper Respiratory Tract Infection

P. C. L. LEE, M. S. M. JAWAD AND R. ECCLES

Common Cold Centre, Cardiff School of Biosciences, University of Wales, Cardiff, UK

◆ a single dose of 30mg dextromethorphan, RCT, 43 patients with URI

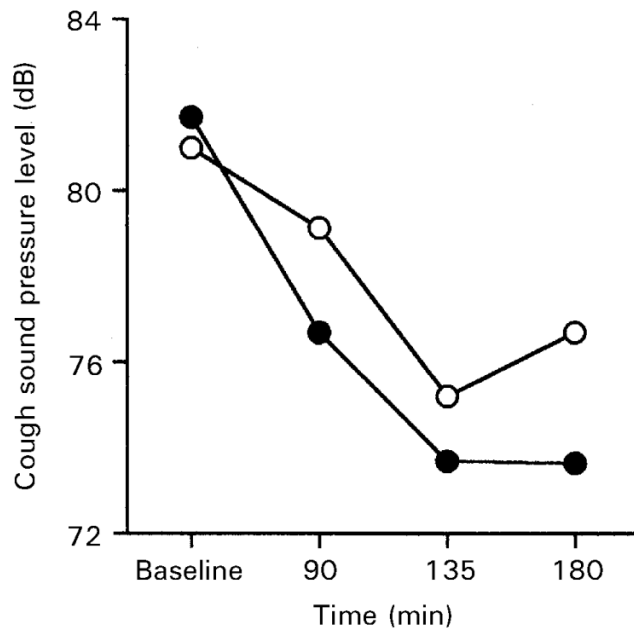

Figure 1. Mean cough sound pressure levels for placebo (○), n = 22) and dextromethorphan (●, n = 21) treatment groups.

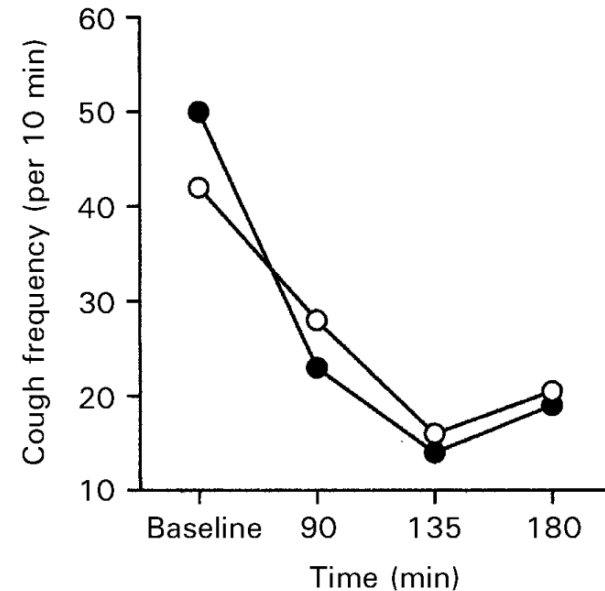

Figure 2. Median cough frequency for placebo (○, n = 22) and dextromethorphan (●, n = 21) treatment groups.

◆ The only statistically significant difference between treatment groups was for the mean cough sound pressure level (CSPL) changes from baseline to 90min (P <0.019)



Levodropropizine for treating cough in adult and children: a meta-analysis of published studies

Alessandro Zanasi^{1*}, Luigi Lanata³, Giovanni Fontana², Federico Saibene³, Peter Dicipinigaitis⁵ and Francesco De Blasio⁴

- ◆ meta-analysis of 7 clinical studies of levodropropizine vs. control, including a total of 1,178 patients
- ◆ Acute bronchitis and lung cancer
- ◆ Absolute Mean Delta was calculated

Table 2 Characteristics of clinical studies comparing levodropropizine to controls in adults

Study	Design	Participants	Intervention vs. comparator	Condition	Outcomes
Allegra 1988	RCT, double-blind Oral administration t.i.d. for 3 days	Adults N = 40 Age: >13 yrs	Levodropropizine vs. placebo	Bronchitis cough	Higher reduction in cough severity with levodropropizine
Catena 1997	RCT, double-blind, double-dummy, two parallel groups Oral administration t.i.d. for 5 days	Adults N = 209 Age: 18–75 yrs	Levodropropizine vs. dextromethorphan	Moderate non-productive cough	Significant reduction in cough frequency with both treatments; Levodropropizine significantly more effective in reducing nocturnal awakenings
Luporini 1998	RCT, double-blind, two parallel groups Oral administration t.i.d. for 7 days	Adults N = 140 > 18 yrs	Levodropropizine vs. dihydrocodeine	Lung cancer cough	Significant reduction in cough severity and nocturnal awakenings with both treatments

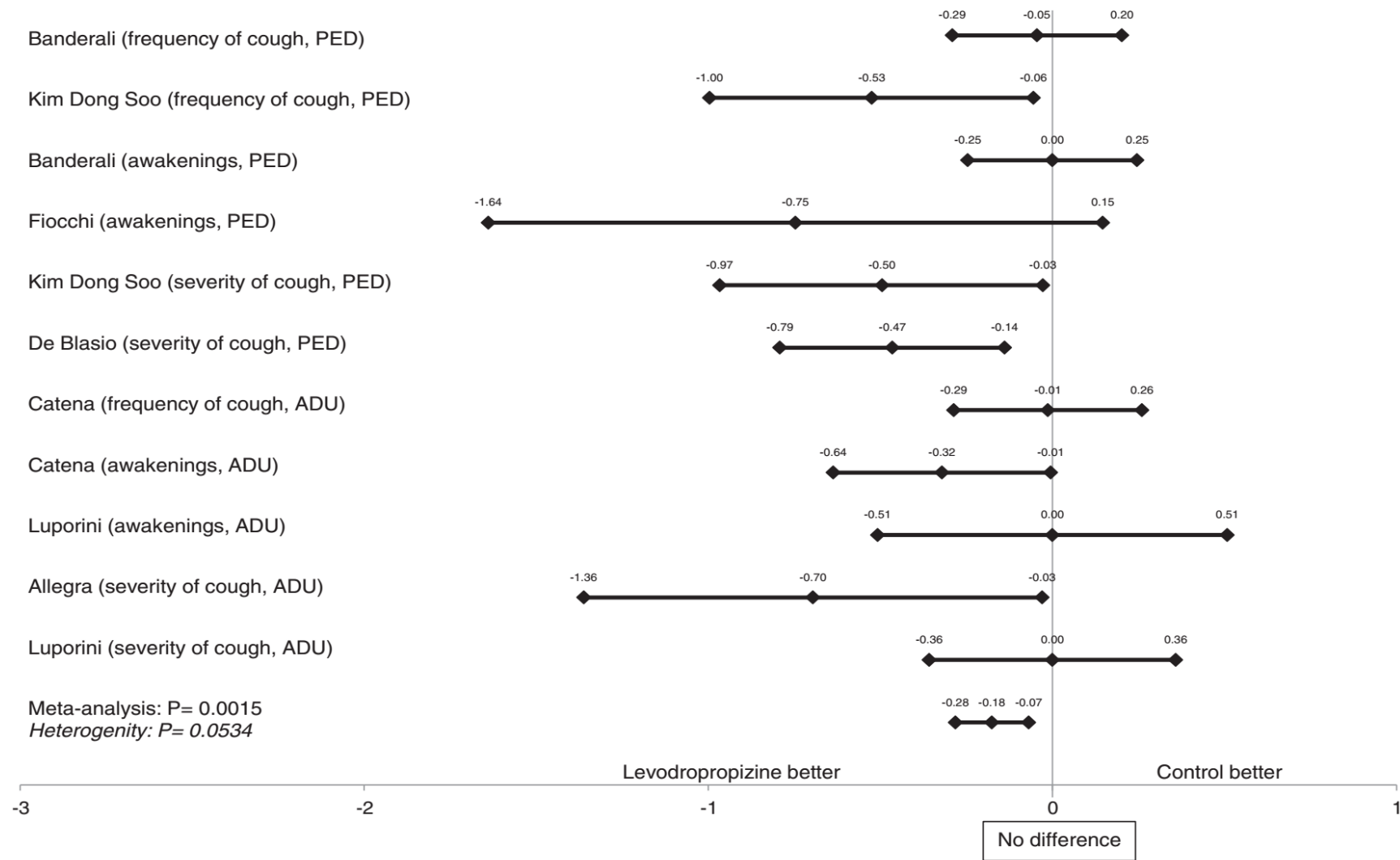

Figure 1 Meta-analysis of the efficacy of levodropropizine vs. controls in pediatric and adult studies.

◆ levodropropizine is an effective antitussive drug in children and adults, with statistically significant better overall efficacy outcomes vs. central antitussive drugs (codeine, cloperastine, dextromethorphan) in terms of reducing cough intensity and frequency, and nocturnal awakenings.

Theobromine

- a methylxanthine derivative present in cocoa.
- theobromine directly inhibits capsaicin-induced sensory nerve depolarization of guinea-pig and human vagus nerve suggestive of an inhibitory effect on afferent nerve activation.
- the actions of theobromine appear to be peripherally mediated.

Antihistamines

- ◆ Limited evidences from double-blind placebo-controlled studies
- ◆ Empiric evidence supports the use of sedating antihistamines for the treatment of cough due to UACS
- ◆ Old studies on the effects of antihistamines for the common cold

Analysis 2.1. Comparison 2 Change in severity of overall symptoms - trials with sedating antihistamines, Outcome 1 Short-term (1 to 2 days).

Review: Antihistamines for the common cold

Comparison: 2 Change in severity of overall symptoms - trials with sedating antihistamines

Outcome: 1 Short-term (1 to 2 days)

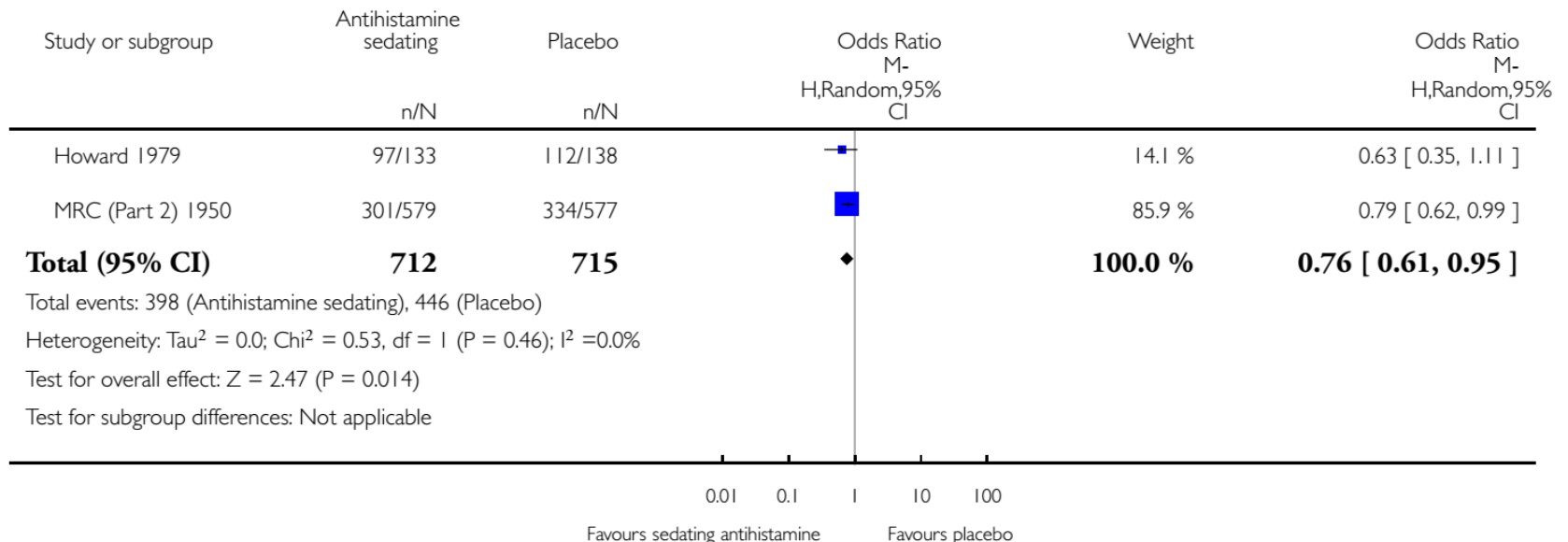

Effect of the second-generation antihistamine, fexofenadine, on cough reflex sensitivity and pulmonary function

Peter V. Dicpinigaitis & Yvonne E. Gayle¹

◆ Twelve healthy volunteers and 12 subjects with URI

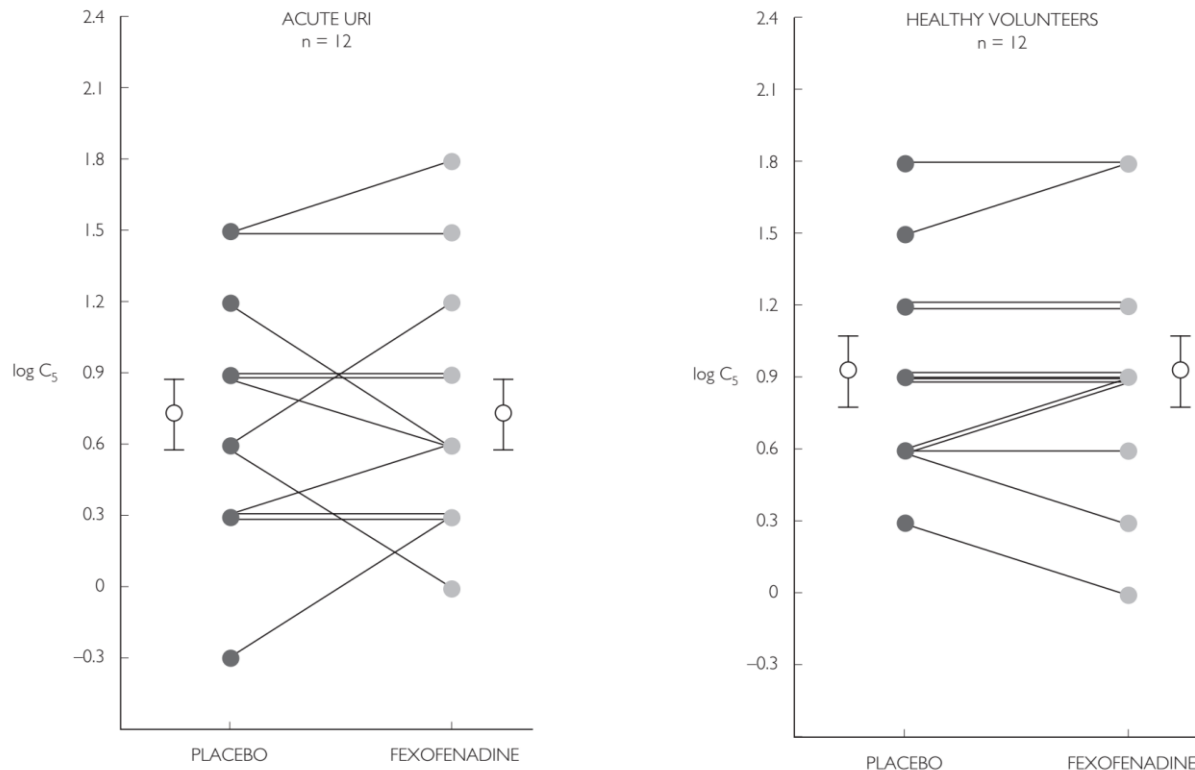

- ◆ Fexofenadine demonstrated no antitussive activity against capsaicin-induced cough in healthy volunteers and subjects with URI.
- ◆ Probably due to the lack of anticholinergic activity and central nervous system penetrance

Inhaled Steroid

- Inhaled budesonide (400mg) bid or placebo for 2 weeks (followed by 2 weeks open trial)
 - ◆ 44 Patients with non-asthmatic non-eosinophilic chronic cough
 - ◆ RCT, Double Blind, Placebo controlled
 - ◆ No improvement in cough discomfort scores after 4 weeks of treatment with budesonide compared to placebo
 - ◆ Because the cause was not associated with sputum eosinophilia

Inhaled corticosteroids for subacute and chronic cough in adults (Review)

Johnstone KJ, Chang AB, Fong KM, Bowman RV, Yang IA

◆ Meta-analysis to assess the effects of ICS for subacute and chronic cough in adults

Figure 4. Forest plot of comparison: I ICS versus Placebo, outcome: I.4 Mean change in cough score.

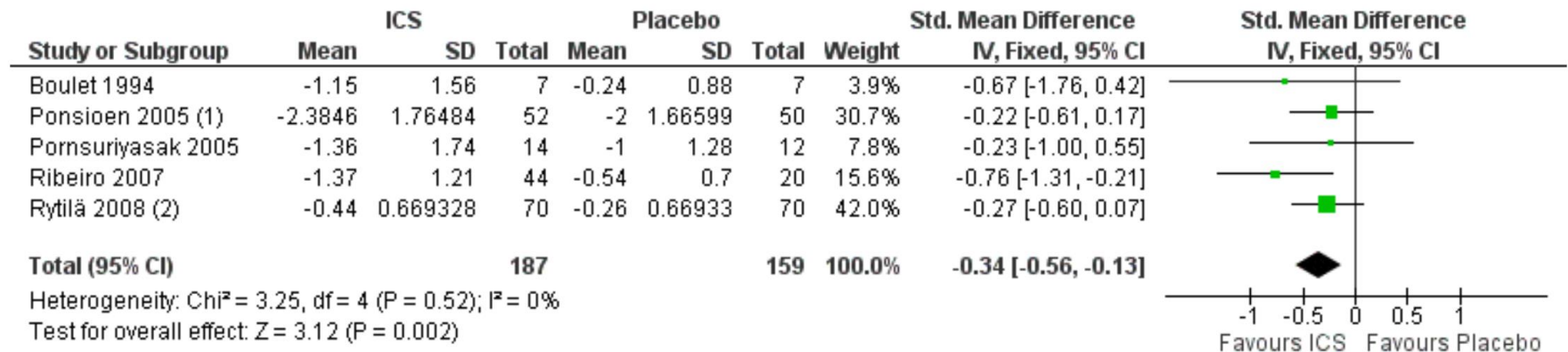

(1) Acute cough patients excluded

(2) Morning cough score

◆ The studies were highly heterogeneous and results were inconsistent.

Long-term Safety of Nebulized Lidocaine for Adults With Difficult-to-Control Chronic Cough

A Case Series

Kaiser G. Lim, MD, FCCP; Matthew A. Rank, MD; Peter Y. Hahn, MD, FCCP;

◆ a retrospective study of adults who received a prescription for nebulized lidocaine for chronic cough

Table 1—Demographic Characteristics of Participants

Variable	Values Overall (N = 99)
Age at examination, median (range), y	62.0 (29.0-87.0)
Female sex, % (No.)	77 (79)
Race/ethnicity, %	
African American	2 (2)
Asian/Pacific Islander	1 (1)
White	81 (82)
Unknown	15 (15)
Education, %	
< 12 grades	2 (2)
High school diploma	37 (38)
Some college	6 (6)
2-y college degree	13 (13)
4-y college degree	15 (15)
> 4 y of college	24 (25)
Cough duration, median (range), y	5.0 (0.1-40.0)
Smoking status, %	
Former	36 (37)
Never	61 (63)
Current	1 (1)

- ◆ All patients were instructed to start with 3 mL of 4% lidocaine (120 mg) bid or tid with the option to increase to 5 mL (200 mg) if numbness of the throat lasted < 20 min
- ◆ The mean (SD) of the pretreatment cough severity score was 8.4 (1.6) and posttreatment was 5.9 (3.4) (P<.001)
- ◆ Of the patients reporting improvement in cough symptoms (49%), 80% reported improvement within the first 2 weeks.

Effect of inhaled menthol on citric acid induced cough in normal subjects

A H Morice, A E Marshall, K S Higgins, T J Grattan

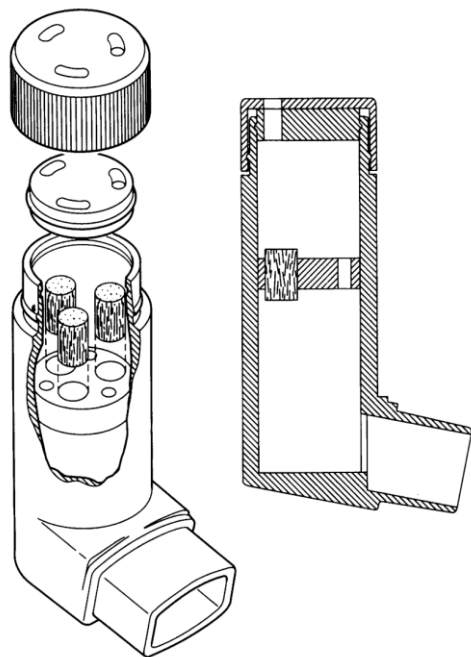

Figure 1 Diagram of the SmithKline Beecham inhalation device for aromatic vapours.

◆ Twenty healthy subjects received a cough challenge consisting of five inhalations of citric acid from an air driven dosimeter.

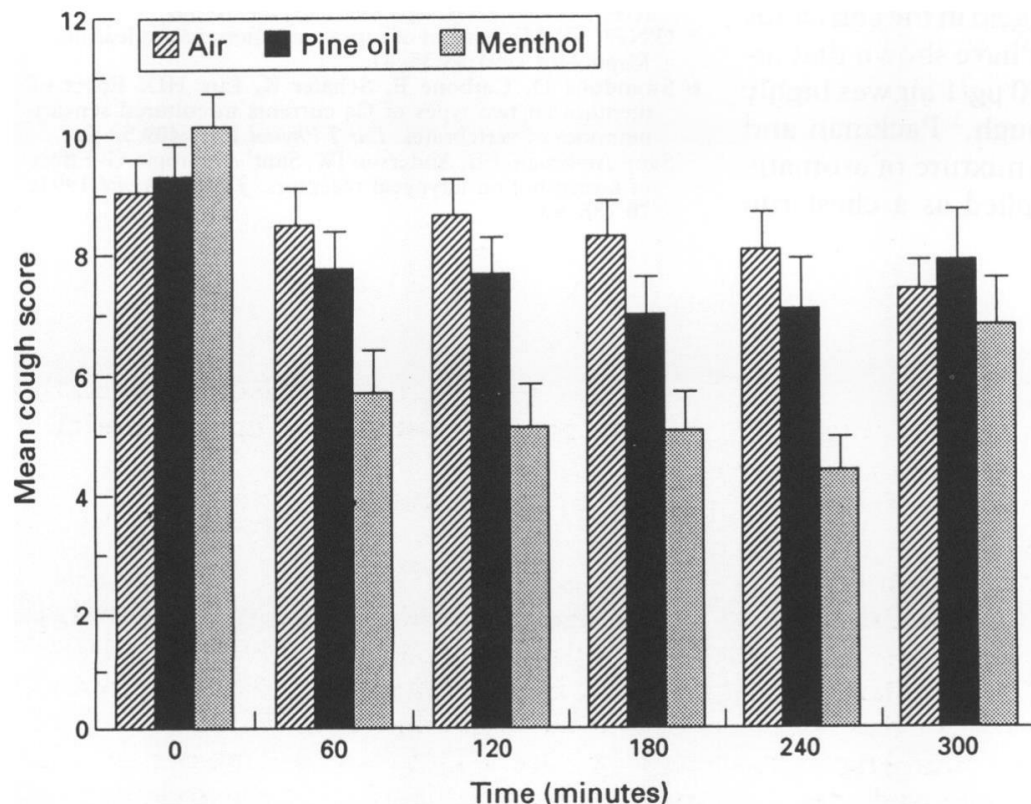

Figure 2 Mean number of coughs following treatment with air, pine oil, and menthol. Significant differences in cough count between menthol and pine oil treatments were seen at one hour ($p < 0.0005$), two hours ($p < 0.0001$), three hours ($p < 0.002$), four hours ($p < 0.0002$), and five hours ($p < 0.05$). Significant differences between menthol and air treatments were seen at one, two, three, and four hours ($p < 0.0001$), but at five hours there was no significant difference.

◆ Menthol inhalation caused a reduction in evoked cough when compared with either placebo.

Cough

A cough will usually go away within 3 weeks on its own.

Treating a cough yourself

Most coughs go away on their own within 3 weeks. There's usually no need to see a doctor.

To help with your cough you can:

- rest
- drink plenty of fluids
- drink hot lemon with honey (not suitable for babies)

Hot lemon with honey has a similar effect as cough medicines.

▶ [How to make hot lemon with honey at home](#)

Effect of Honey on Nocturnal Cough and Sleep Quality: A Double-blind, Randomized, Placebo-Controlled Study

- ◆ Children with upper respiratory tract infections (URIs)
- ◆ a single nocturnal dose of 3 honey products (eucalyptus honey, citrus honey, or labiatae honey) vs. placebo (silan date extract)

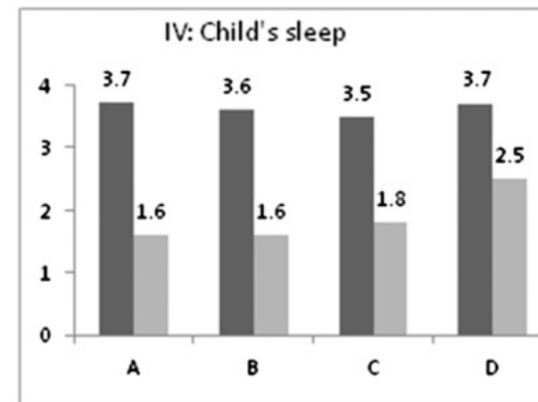
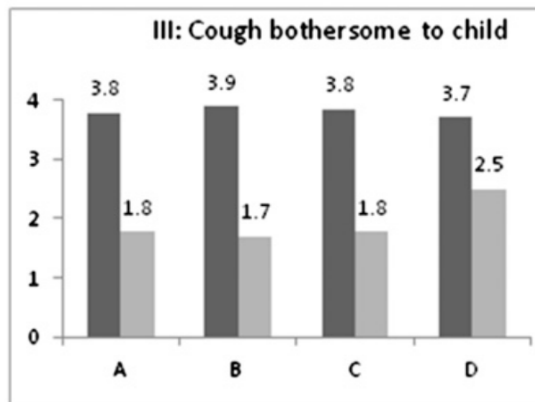
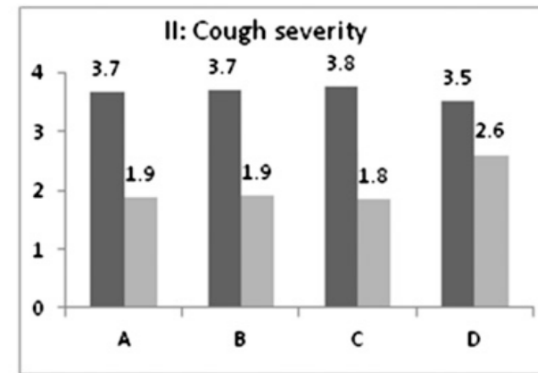
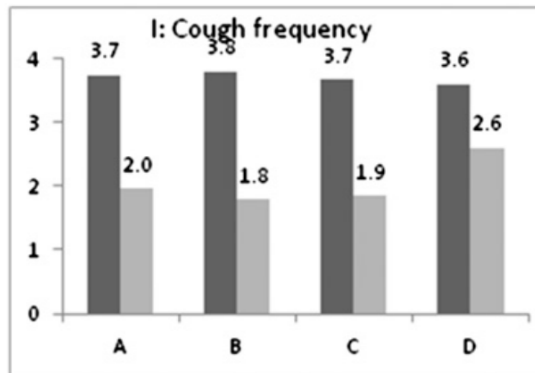

- ◆ A significant improvement from the night before treatment to the night of treatment
- ◆ The improvement was greater in the honey groups for all the main outcome measures

Gabapentin for refractory chronic cough: a randomised, double-blind, placebo-controlled trial



Nicole M Ryan, Surinder S Biring, Peter G Gibson

- ◆ 62 non-smokers with a cough of more than 8 weeks' duration and without specific causes of cough
- ◆ gabapentin (maximum tolerable daily dose of 1800 mg) or matching placebo for 10 weeks.
- ◆ objective serial assessments of cough severity, sensitivity and quality of life

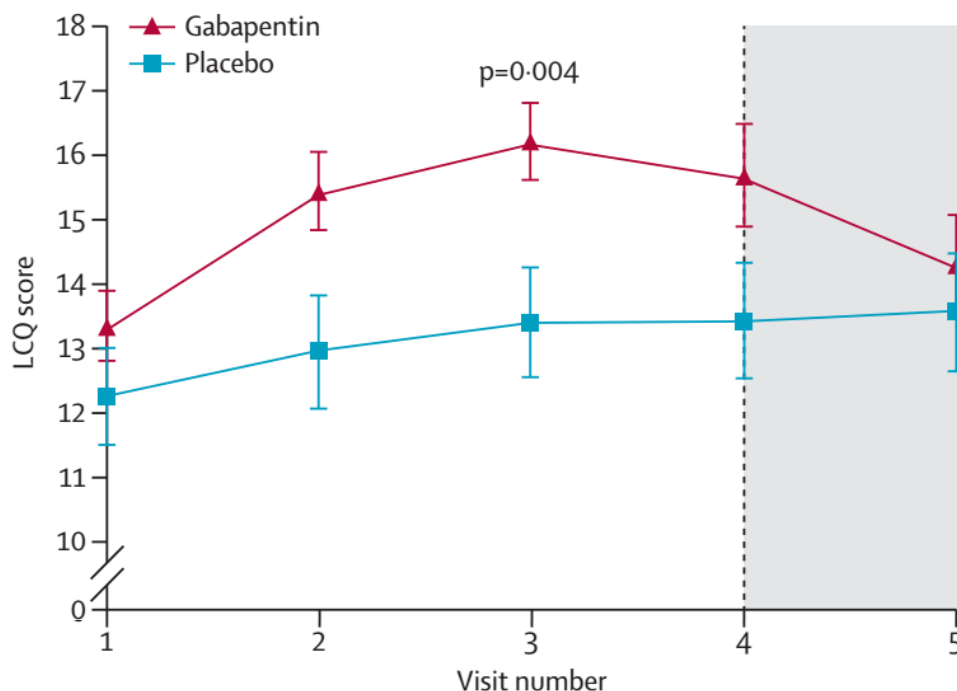

- ◆ gabapentin significantly improved cough-specific quality of life compared with placebo
- ◆ Side-effects occurred in ten patients (31%) given gabapentin (the most common being nausea and fatigue) and three (10%) given placebo

Sensory Laryngeal Neuropathy (Central Sensitization)

- ◆ Central reflex sensitization symptoms included **abnormal laryngeal sensations** consistent with laryngeal paraesthesia, such as sensations of throat irritation, tickle, tightness, presence of mucus, and the sensation of something sticking in the throat

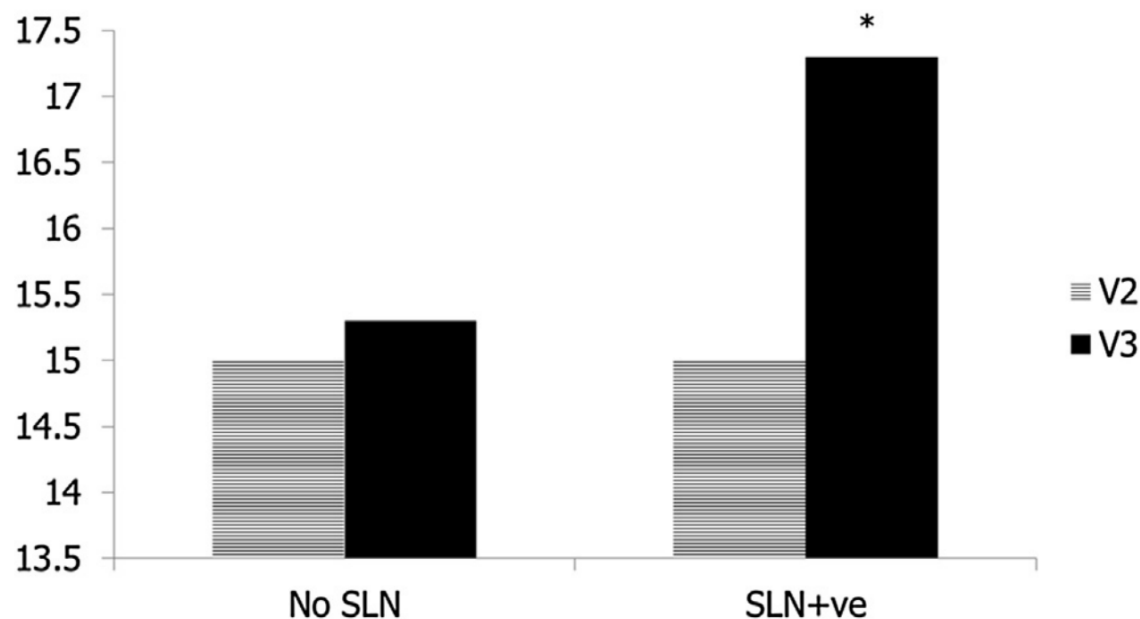

Fig. 1. Effect of gabapentin on cough quality of life (Leicester cough questionnaire score, y-axis) before (hatched bars) and after (solid bars) gabapentin in patients with refractory chronic cough with (SLN+) and without (SLN-) symptoms of sensory laryngeal neuropathy.

- ◆ Gabapentin has been shown to be well tolerated and effective in treating refractory chronic cough associated with sensory neuropathy

COUGH

Efficacy of speech pathology management for chronic cough: a randomised placebo controlled trial of treatment efficacy

A E Vertigan, D G Theodoros, P G Gibson, A L Winkworth



Thorax 2006;**61**:1065–1069. doi: 10.1136/thx.2006.064337

Table 2 Examples of strategies in the treatment programme

Component	Example
Education	No physiological benefit from cough; capacity for voluntary cough control
Strategies to reduce cough	Identify warning signs for cough and replace with modified swallow technique, pursed lip breathing exercise, or relaxed throat breath
Reduce laryngeal irritation	Increase hydration, decrease exposure to irritating stimuli
Psycho-educational counselling	Internalising locus of control; acceptance that treatment is hard work; setting realistic goals

- ◆ A single blind, randomised, placebo controlled trial
- ◆ 87 patients with chronic cough
- ◆ Participants in both groups attended four intervention sessions with a qualified **speech pathologist**

COUGH

Efficacy of speech pathology management for chronic cough: a randomised placebo controlled trial of treatment efficacy

A E Vertigan, D G Theodoros, P G Gibson, A L Winkworth



Thorax 2006;**61**:1065–1069. doi: 10.1136/thx.2006.064337

Table 6 Comparison of clinical judgement of outcome of the intervention between treatment and placebo groups (χ^2 test)

Outcome	Treatment (N = 43)	Placebo (N = 44)	p value
Successful	38	6	<0.001
Unsuccessful	2	35	
Partially successful	3	3	

- ◆ Speech pathology is an effective management intervention for chronic cough which may be a viable alternative for patients who do not respond to medical treatment.

Pregabalin and Speech Pathology Combination Therapy for Refractory Chronic Cough

A Randomized Controlled Trial

- ◆ Forty patients with Chronic refractory cough (CRC)
- ◆ combined SPT and pregabalin 300 mg daily vs. combined SPT and placebo

Cough severity

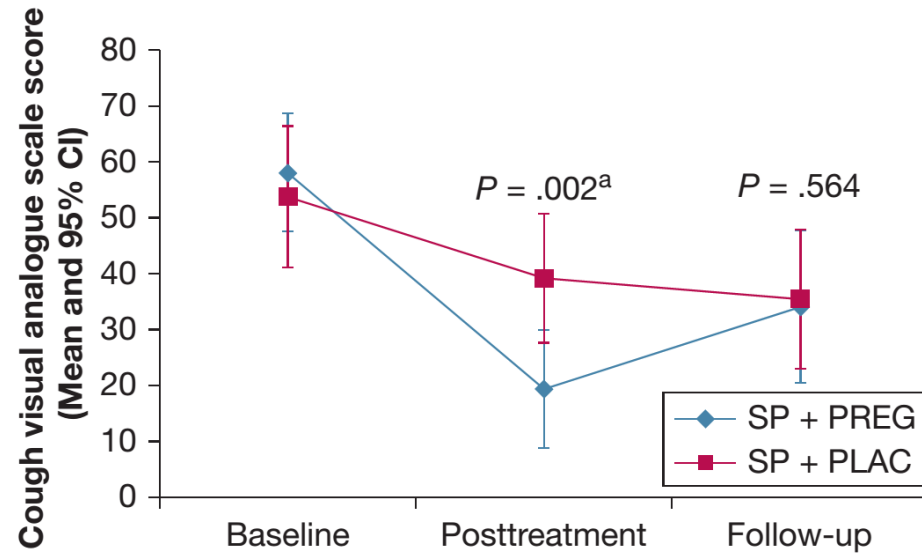

Leicester cough questionnaire scores

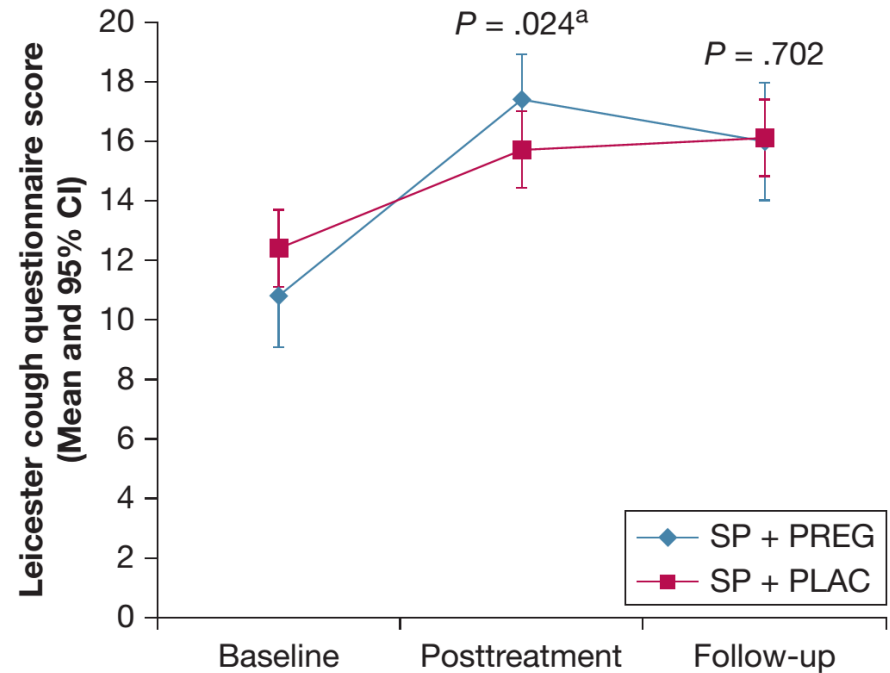

- ◆ Combined SPT and pregabalin reduces symptoms and improves QOL compared with SPT alone in patients with CRC

Symptomatic Treatment of Cough Among Adult Patients With Lung Cancer

CHEST Guideline and Expert Panel Report



TABLE 3] Indicative Doses for Antitussives, Demulcents, and Topical Anesthetics^a

Medication	Dosage
Simple linctus	5 mL tid or qid
Dextromethorphan	10-15 mg tid or qid (10-30 mg in some publications, maximum dose of 120 mg/d)
Codeine	30-60 mg qid
Pholcodine	10 mL qid
Morphine (Oramorph)	5 mg (single-dose trial of Oramorph; if effective 5-10 mg slow-release morphine bid)
Diamorphine	5-10 mg subcutaneously/24 hrs
Methadone linctus	Single dose 2 mg (2 mL of 1 mg/mL solution)
Dihydrocodeine ^b	10 mg tid
Hydrocodone	5 mg bid
Inhaled cromoglycate	10 mg qid
Levodropropizine ^b	75 mg tid
Moguisteine ^b	100-200 mg tid
Levocloperastine ^b	20 mg tid
Nebulized lidocaine ^c	5 mL of 0.2 tid
Nebulized bupivacaine ^c	5 mL of 0.25% tid
Benzonatate ^b	100-200 mg qid
Prednisolone	30 mg daily for 2 wk